

# ERAENT

MAKING MILLIMETERWAVE ACCESSIBLE

## MILLIMETER WAVE VNA EXTENDERS AND CALIBRATION KITS

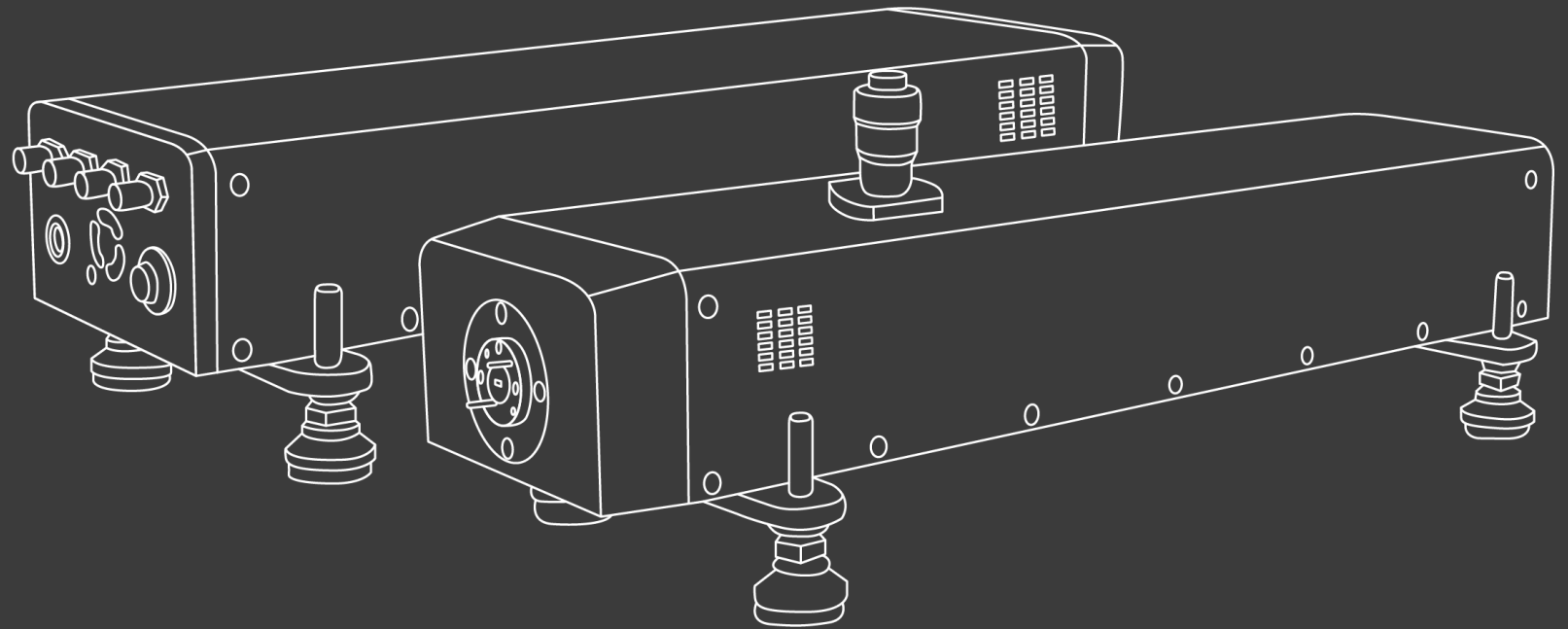

January 16, 2023

# CONTENTS

---

INTRODUCTION

WHY ERAVANT?

PRODUCT PHOTOS

SYSTEM BLOCK DIAGRAM

PERFORMANCE

COMPATIBILITY

VNA CALIBRATION KITS

CONCLUSIONS

# INTRODUCTION

- Vector Network Analyzers are widely used in the RF and Microwave electronics industries. Coaxial VNAs operating up to 50 GHz are widely available.
- As millimeter wave technology finds increasing applications in 5G, 6G, Space, Communications, Radar and elsewhere, the demand for improved mm-wave test capability also increases.
- VNAs with built-in test capability above 50 GHz are uncommon and expensive. Adding frequency extenders to an existing VNA is often a more practical and affordable strategy for reaching higher frequencies.
- Many VNA models from manufacturers such as Keysight, Rhode & Schwarz, Anritsu, and Copper Mountain are compatible with mm-wave frequency extenders.
- Some frequency extenders are sourced by the VNA manufacturer and sold as optional equipment. More commonly, they are offered by third parties such as Oleson Microwave Labs, Farran, and Virginia Diodes.

# WHY ERAVANT?

- Eravant offers high-performance and cost-effective VNA frequency extenders, drawing from an extensive range of broadband components and a history of subsystem design achievements.
  - Eravant's extenders have similar or superior dynamic range compared to other suppliers.
  - Eravant's price and delivery are more competitive.

Model (TX/RX Pair)	Frequency Range (GHz)	Band	Output Power (dBm)	Dynamic Range (dB)	RF Source Frequency (GHz)
STO-03203N05-CMC-S1	220 to 330	J	-35 to -5	110	12.2 to 18.3
STO-0520300-CMC-S1	140 to 220	G	-30 to 0	110	11.7 to 18.3
STO-0620300-CMC-S1	110 to 170	D	-30 to 0	110	9.2 to 14.2
STO-0820300-CMC-S1	90 to 140	E	-30 to 0	110	11.3 to 17.5
STO-1020313-CMC-S1	75 to 110	W	-17 to +13	120	12.5 to 18.3
STO-1220315-CMC-S1	60 to 90	E	-15 to +15	120	10 to 15
STO-1520315-CMC-S1	50 to 75	V	-15 to +15	120	12.5 to 18.8

# PRODUCT PHOTOS

(With Copper Mountain Model C4209)



# PRODUCT PHOTOS

(With Rhode & Shwartz Model ZAV24)

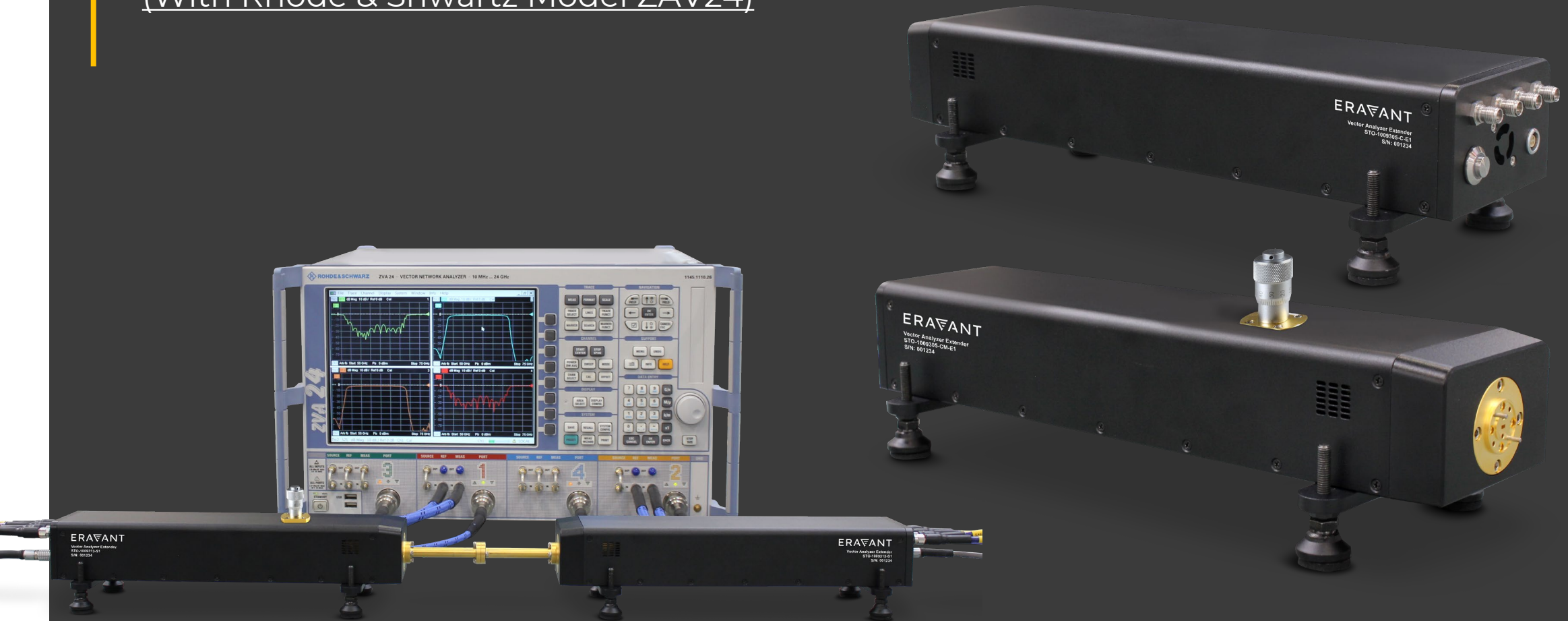

# SYSTEM BLOCK DIAGRAM

- Eravant's VNA extenders are offered as pairs of TX/RX modules, or as separate TX/RX, TX/Ref, or RX modules
- A pair of TX/RX modules provides full two-port measurement capability
- A single TX/RX module measures  $S_{11}$
- A TX/RX module paired with an RX module measures  $S_{11}$  and  $S_{21}$
- TX/Ref and RX units measure Response

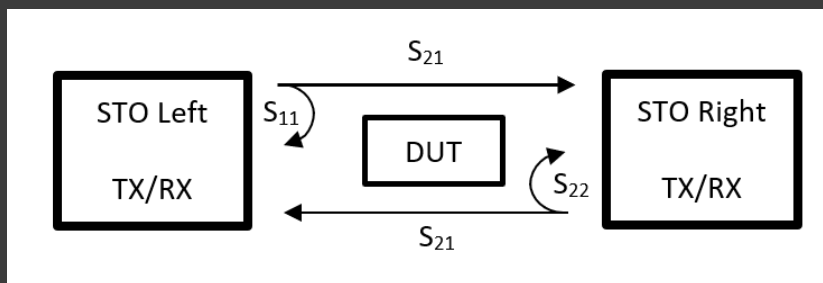

Simplified Block Diagram

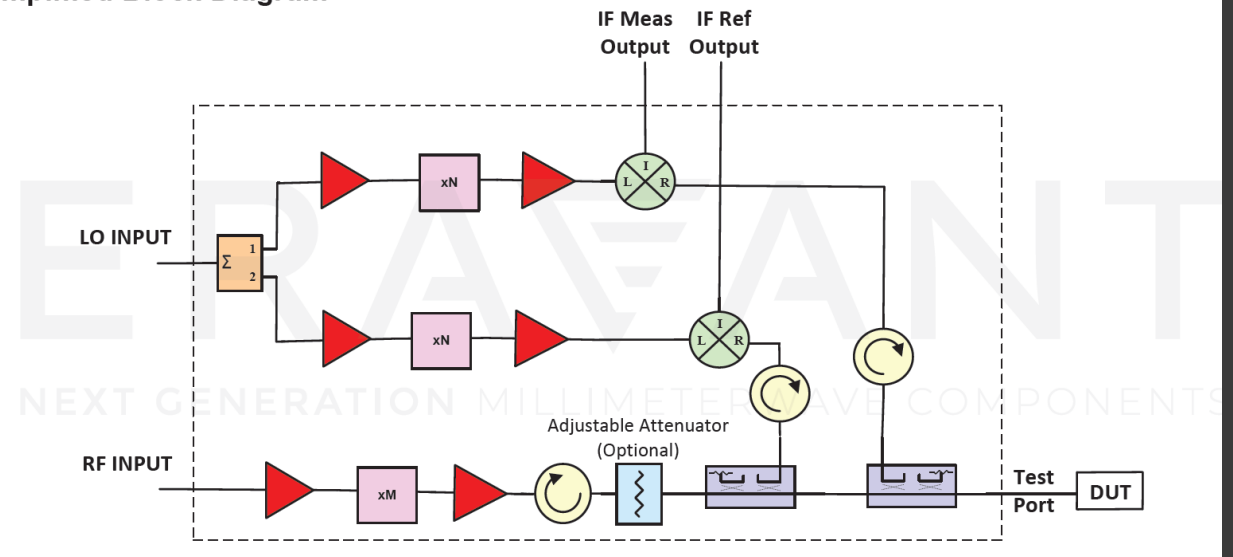

# PERFORMANCE

- Evarant's VNA extenders offer 110 to 120 dB of Dynamic Range

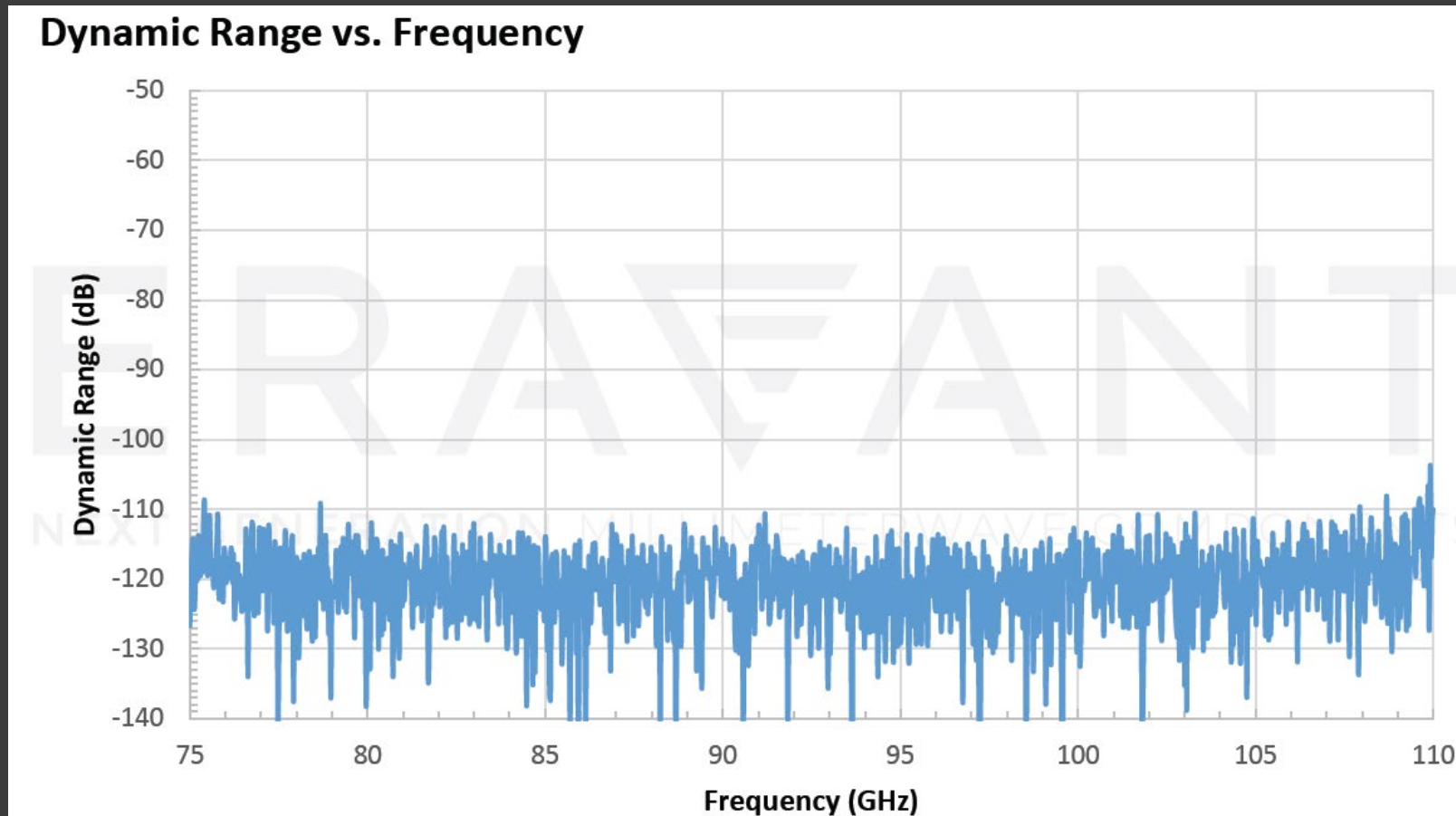



# COMPATIBILITY

Evarant's VNA extenders are compatible with leading VNA OEMs including Keysight, Rhode & Schwarz (R&S), Anritsu, and Copper Mountain Technologies (CMT).

- Compatible VNAs provide LO signals and access to their IF channels to process down-converted mm-wave test signals
- Compatible VNAs also include software functions that provide easy setup, calibration, operation, and verification of the extended instrument
- Evarant's frequency extenders have been qualified by VNA manufacturers to ensure compatibility, reliability and accuracy

# VNA CALIBRATION KITS

Eravant's VNA Calibration Kits cover waveguide bands from 18 to 330 GHz.

- Beryllium Copper for durability
- Precisely Machined
- NIST traceable calibration data is available for an additional fee

Anritsu and Copper Mountain have qualified the calibration kits for their VNA product lines

Complete VNA Calibration kit specifications can be obtained from the [Eravant Website](#)



# Proxi-Flange™

## Contactless Waveguide Flanges

Proxi-Flange contactless waveguide flanges eliminate the need to tighten waveguide screws during calibration and testing operations

- Patent-pending choke designs suppress signal leakage at waveguide interfaces
- Gaps up to several mils can be tolerated
- Calibration and testing times can be greatly reduced with negligible loss of accuracy
- Operator fatigue is reduced
- Measurement reliability is improved
- Mechanical stress on tested components and VNA test ports is eliminated



# Wave-Glide™ Sliding Rail Positioning Systems

Wave-Glide sliding rail positioning systems maintain precise alignment between the VNA test ports on frequency extender modules

- Sliding platforms are compatible with all VNA frequency extenders
- The platforms are easily modified to accommodate a wide range of instruments
- Alignment is achieved using precision tuning screws
- Custom configurations are available
- Measurement speed and reliability are improved
- Maximum benefits are realized when Wave-Glide is combined with Proxi-Flange contactless flanges

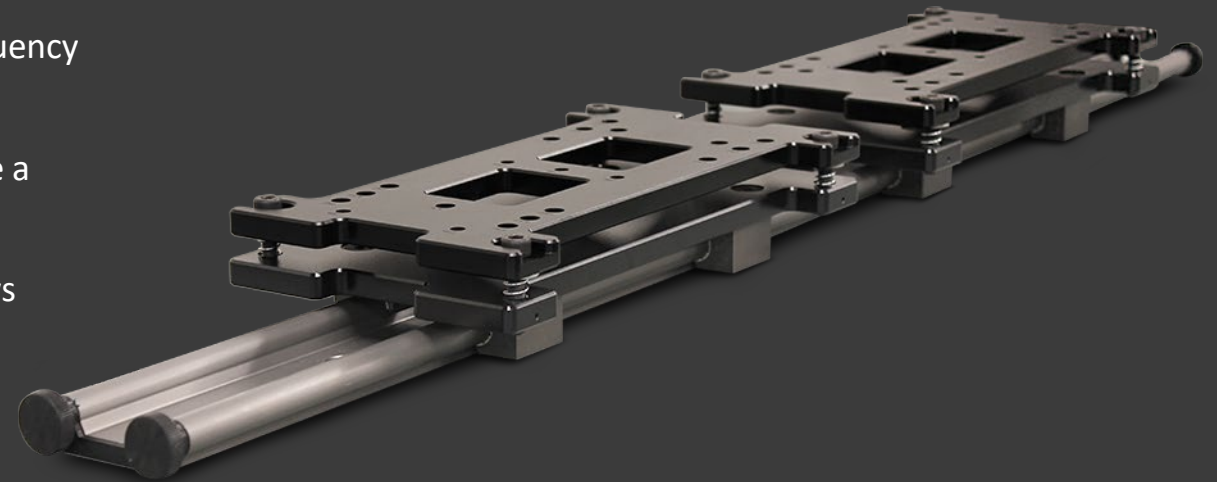

# CONCLUSION

- High-performance and cost-effective VNA frequency extenders have been used in Eravant production lines for several years.
- Eravant VNA frequency extenders are qualified by all leading VNA OEMs.
- They are compatible with Keysight PNA-X series, Rhode & Schwarz (R&S) ZVA24 series, Anritsu VectorStar, and Copper Mountain C4220 VNAs. Eravant VNA Extenders are under evaluation for other VNA manufacturers and models.
- High-performance and cost-effective VNA calibration kits are also qualified by Anritsu, Copper Mountain, and others.
- The competitive edges of Eravant VNA extenders and calibration kits include comparable or superior performance, higher build quality, lower cost and faster delivery. These features make millimeter-wave testing more affordable and more productive.
- VNA frequency extenders combined with Eravant's patent-pending and trademarked contactless flange and rail systems offer complete, accurate and productive millimeter-wave VNA test solutions. [Further information on the contactless flange and rail system can be found here.](#)

