

# ERAVANT

NEXT GENERATION MILLIMETERWAVE COMPONENTS

ERAVANT SPACE HERITAGE

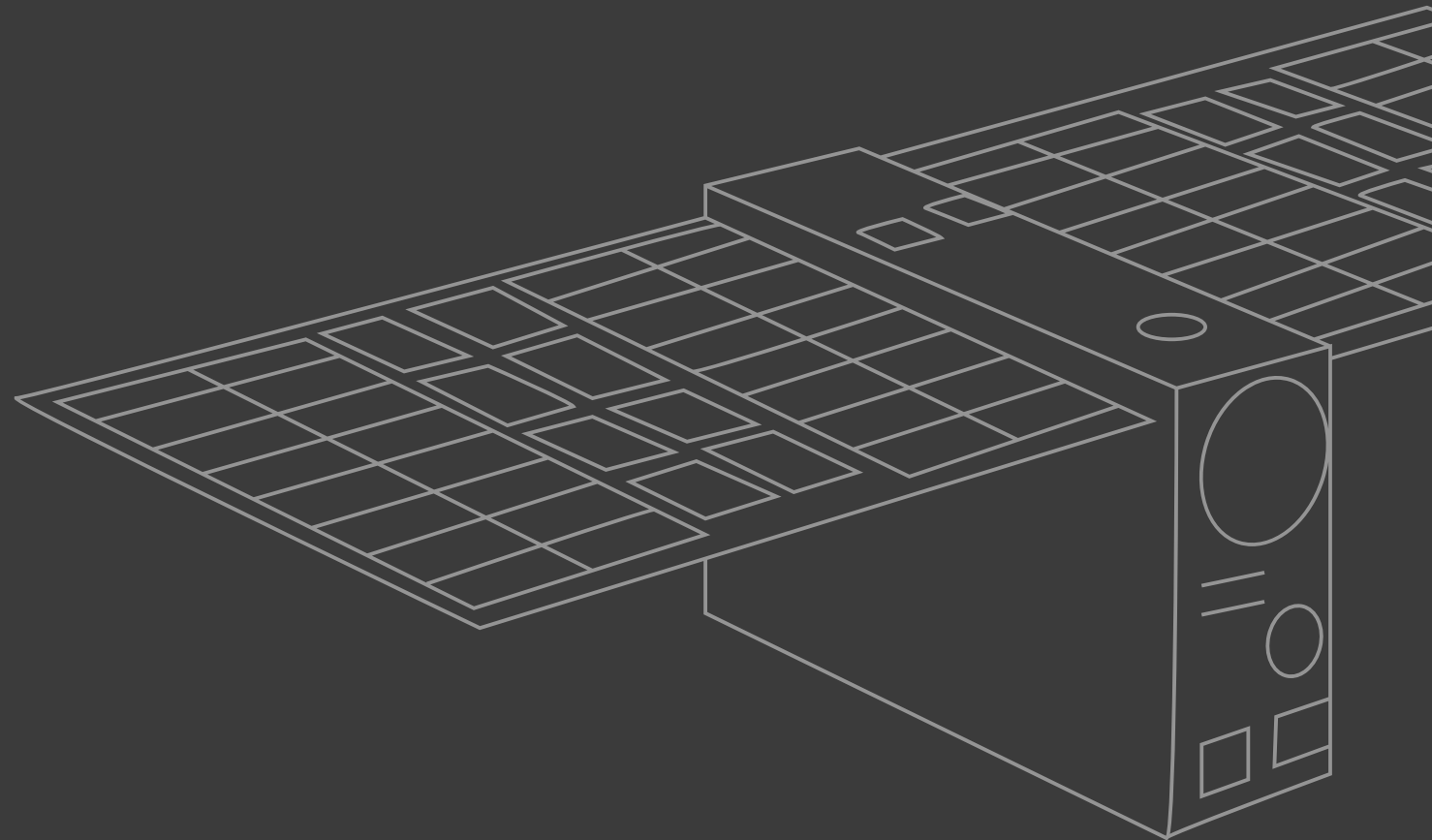

# CONTENTS

---

INTRODUCTION

PERSEUS-M SATELLITE

ARGOMOON SATELLITE

OTHER SPACE HARDWARE

CONCLUSION

# INTRODUCTION

**ERAVANT**, formally SAGE Millimeter, Inc. was founded in 2011 and is a technology company with a focus on developing high performance microwave and millimeterwave components and subassemblies for commercial and military system applications. Eravant's product offerings range from standard catalog products to custom designed, application, performance, and/or function specific products in the primary frequency range of 18 to 220 GHz.

Located in Torrance, California, Eravant is adjacent to leading aerospace, defense, and telecommunication companies as well as research laboratories and universities. Eravant can take advantage of highly specialized experts, experienced professionals, skilled work force, and diversified vendors, while working closely with the industry leaders to design, develop, and produce many state-of-the-art high performance and application-oriented products.

Eravant has delivered more than 50,000 components and hardware for commercial, military, and space applications since its inception. The presentation shall review successful flight programs that incorporated Eravant hardware.

# PERSEUS-M SATELLITE

# BACKGROUND

- The **Perseus-M** satellites are small maritime surveillance satellites developed by Canopus Systems US, a US American independent affiliate of the Russian Dauria Aerospace.
- The Perseus-M satellites are built as pathfinder satellites to the CubeSat (6U) standard and feature an Automatic Identification System (AIS) receiver provided by LuxSpace, similar to Dauria's DX1 prototype satellite.
- Dauria and Canopus Systems also planned to launch eight optical Perseus-O earth observation satellites in late 2015, but this was cancelled.
- Eravant was contracted to develop and deliver the space qualified Ka Band Transmitter and Antenna Assembly for the satellite in a time window of **six** months.

# Ka - BAND TRANSCIVER & ANTENNA ASSEMBLY

- On October 08, 2013, Eravant received a contract to develop and deliver **seven** flight Ka band ITA (Integrated Transmitter Assembly) and lens antenna/polarizer assemblies (LAPA) for Canopus System, USA. On October 16, 2015, Eravant received a follow up contract from Aquila Space (Formally known as Canopus System, USA) for an additional **five** flight units.
- The hardware was a custom designed sub-assembly for **Perseus-M** satellites, which are small maritime surveillance satellites.
- On February 28, 2014, five months after the reception of the contract, Eravant successfully developed and delivered all seven modules. On July 19<sup>th</sup>, 2014, Two ITA and LAPA modules were launched into space via Vehicle Dnepr's successful launch. The link [here](#) shows the details.
- The technical details were presented in [2017 IEEE TWIoS \(RWW\)](#).

# Ka - BAND TRANSCIVER & ANTENNA ASSEMBLY

Item	Description	Limits	Measured
1	IF Frequency Range (MHz)	900 to 1,100	900 to 1,100
2	RF Frequency Range (GHz)	26.7 to 26.9	26.7 to 26.9
3	Input Power (dBm, Typical)	+ 4.0	+2.0
4	P-1 dB @ Output (dBm, Minimum)	+27	+28.5
5	Power Monitoring (mV, Typical)	+2,000 mV	2,300 mV
6	RF Port VSWR (Max)	1.5:1	1.48:1
7	IF Port VSWR (Max)	1.5:1	1.40:1
8	2 <sup>nd</sup> Harmonic Level (dBc, Max)	-50	Comply
9	Spurious and 3 <sup>rd</sup> Harmonic Level (dBc, Max)	-60	Comply
10	Frequency Stability (ppm, Max)	± 20	- 7.5
11	Local Oscillator Phase Noise (Max)	-80 dBc/Hz @ 1 KHz -88 dBc/Hz @ 10 KHz -100 dBc/Hz @ 100 KHz -115 dBc/Hz @ 1 MHz	-110 dBc/Hz -103 dBc/Hz -101 dBc/Hz -116 dBc/Hz

Table 1. Ka Band ITA Measured vs. Specified Performance

# Ka - BAND TRANSCIVER & ANTENNA ASSEMBLY

Item	Description	Limits	Comment
12	Bias Voltage/Current (Vdc/Amp, Max)	+8/1.5	+8/1.32
13	RF Connector	WR-28 with UG599/U	Comply
14	IF Connector	SMA(F)	Comply
15	DC and Monitoring Connector	Micro-D, 15 Pins, TTL Phase Error, TX Power	Comply
16	Operating Temperature (°C)	-25 to +65	Comply
17	Storage Temperature (°C)	-40 to +85	Comply
18	Vacuum Operation (Max)	1.0 x 10E-16	TBD
19	Design for Rugged Environment	No Specific Vibration Specifications Provided	TBD

Table 1. Ka Band ITA Measured vs. Specified Performance (Continued)



# Ka-BAND TRANSCIEVER & ANTENNA ASSEMBLY

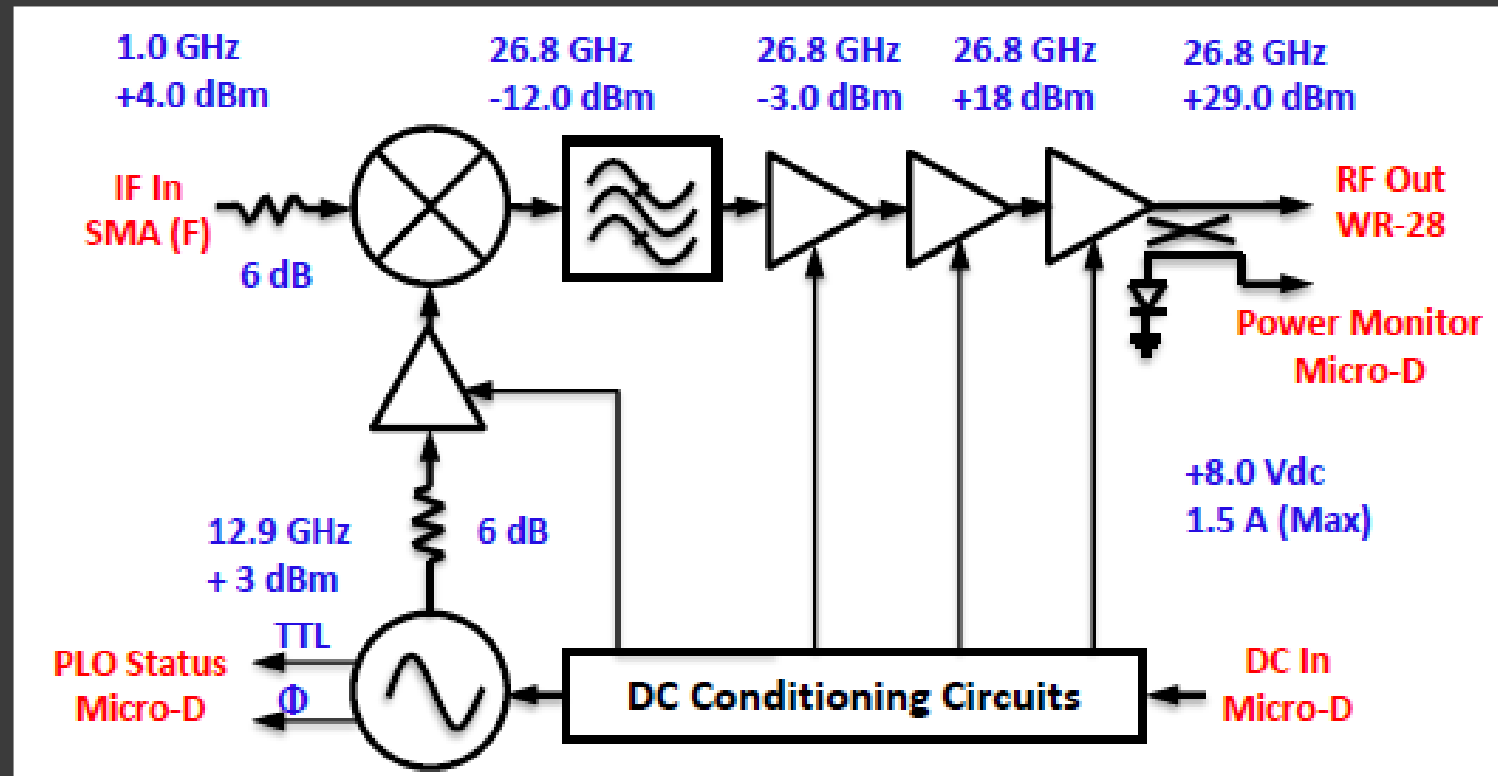

Figure 1. Ka Band ITA Block Diagram

# Ka-BAND TRANSCIEVER & ANTENNA ASSEMBLY

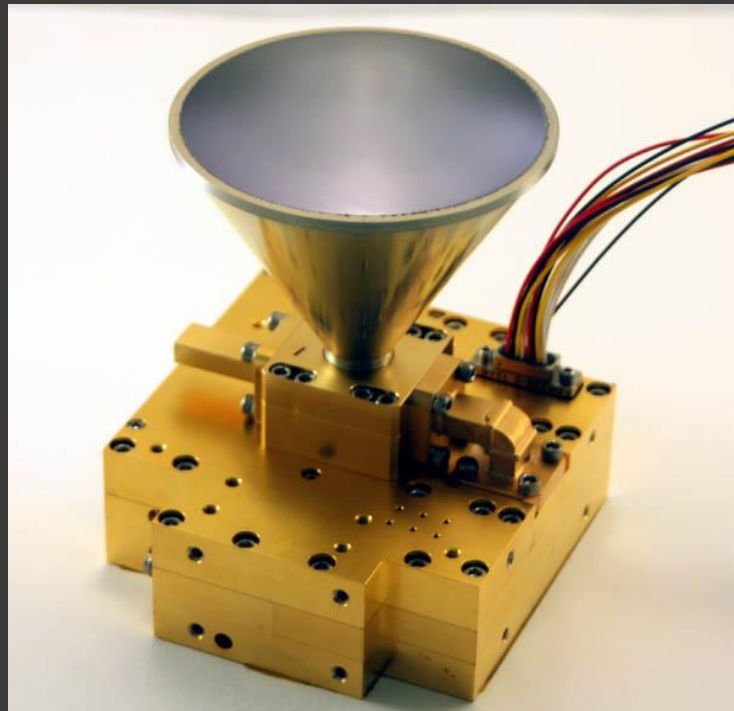

Figure 2. Ka Band ITA and LAPA Assembly

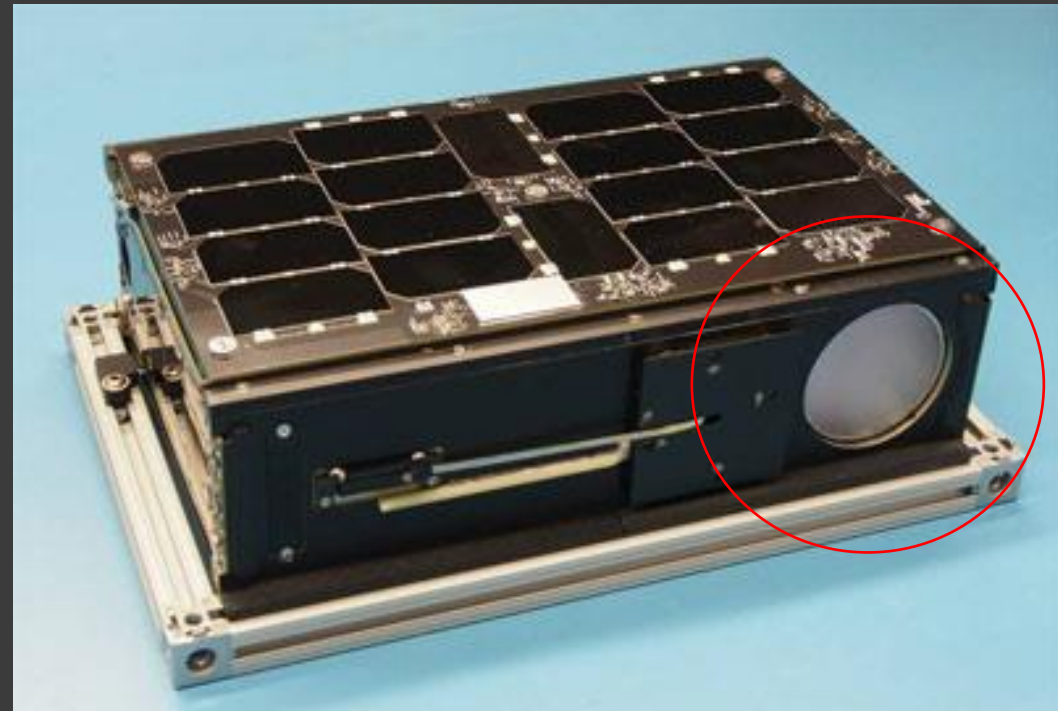

Figure 3. Perseus-M Satellite with the Ka band ITA and LAPA Integrated

# ARGOMOON

# BACKGROUND

- ArgoMoon was a 6U CubeSat deep-space mission of ASI (Italian Space Agency). ESA had selected the ArgoMoon CubeSat of ASI to fly in 2020 on NASA's Orion EM-1 (Exploration Mission-1) maiden flight along with 12 other Cubesats, powered by NASA's newly developed SLS (Space Launch System).

*"This could be the first European CubeSat to leave Earth orbit and we are looking forward to it capturing historic images of the first Orion mission,"*

- David Parker, ESA Director of Human Spaceflight and Robotic Exploration.

- The primary goal of the mission was to take detailed photographs of the SLS secondary propulsion stage. After that, orbital maneuvers would be performed to move the satellite into a geocentric highly elliptical orbit, whose apogee was high enough to allow flybys and imaging of the Moon and the surrounding environment.
- Eravant was contracted to develop and deliver the space qualified C and X Band patch antennas for the satellite in a time window of **three** months.

# C-BAND AND X-BAND PATCH ANTENNAS

- On July 28, 2017, Eravant received a contract to develop and deliver **two of each** flight X band microstrip patch antennas, 7 and 8 GHz, for Argotec S.r.l.
- The 7 GHz microstrip antenna was referred to interchangeably as the C-Band or X-Band antenna 1
- The hardware included custom X band microstrip patch antennas for the **ArgoMoon** satellite.
- On October 28, 2017, three months after the reception of the contract, Eravant successfully developed and delivered both antennas. One of each was installed in the ArgoMoon satellite system and the satellite was launched into the orbit in 2020. The link [here](#) shows the details.



Figure 4. X-Band Patch Antenna Photo

# C-BAND AND X-BAND PATCH ANTENNAS

Item	Descriptions	Limits
1	Frequency Range	7,145 to 7,235 GHz
2	Gain	8.0 dBi
3	3 dB Beamwidth	65 x 65 Degrees
4	Polarization	Linear
5	VSWR	2:2
6	RF Connector	SMA (F)
7	Power Handling	50 Watts
8	Number of Elements	1
9	Dimensions	1.10" (L) x 1.10" (H) x 0.64" (W)

Table 2. X Band Antenna 1 Performance

Item	Descriptions	Limits
1	Frequency Range	8,400 to 8,500 GHz
2	Gain	8.0 dBi
3	3 dB Beamwidth	65 x 65 Degrees
4	Polarization	Linear
5	VSWR	2:2
6	RF Connector	SMA (F)
7	Power Handling	50 Watts
8	Number of Elements	1
9	Dimensions	1.10" (L) x 1.10" (H) x 0.64" (W)

Table 3. X Band Antenna 2 Performance

# C-BAND AND X-BAND PATCH ANTENNAS

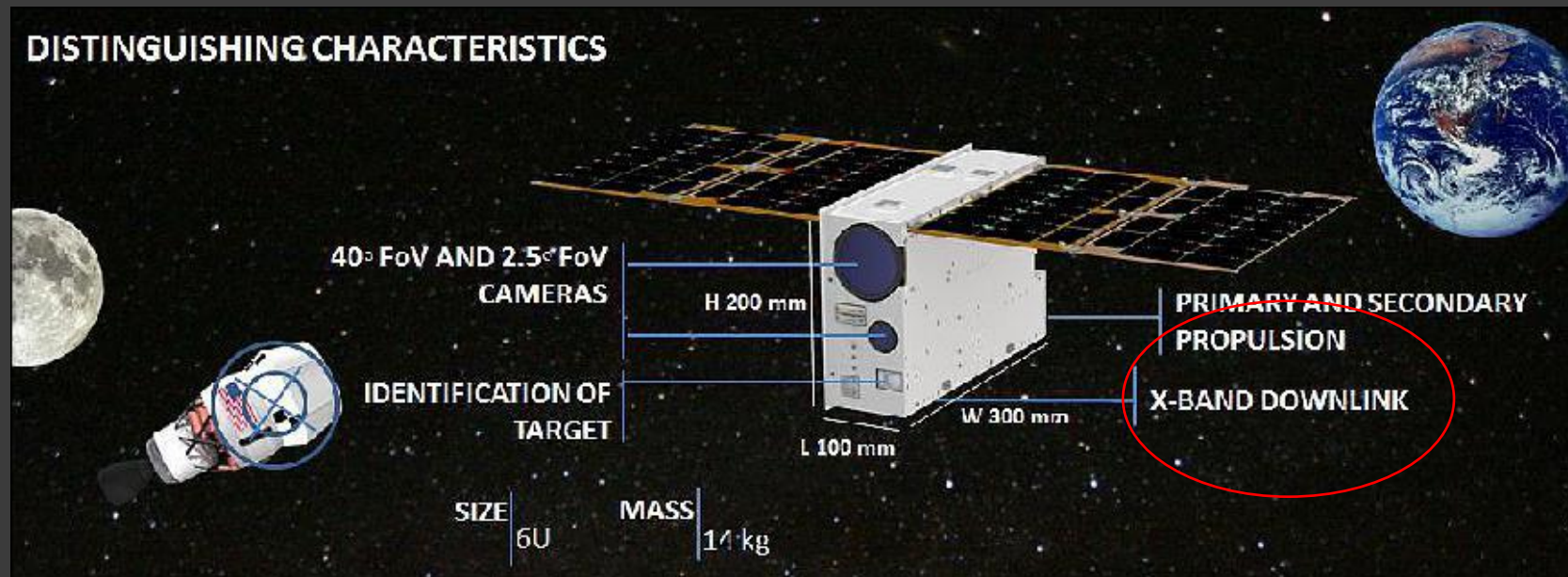

Figure 5. ArgoMoon Satellite with the X-Band Antenna Installed

# OTHER SPACE HARDWARE



# OTHER SPACE HARDWARE

- Eravant offers Total Product Solutions to configure any system applications in the Frequency Range of DC to 220 GHz.
- Although the standard models may NOT be specifically designed and manufactured for Space and Thermal Vac (T-Vac) applications, many of them can be updated to T-Vac grade by simply updating the manufacturing process and utilizing “no-outgassing” materials, such as the type of adhesive, OFHC copper or stainless steel, etc. The models with the “-V” suffix are updated and delivered for Thermal Vac applications. The examples are:
  - SAR, SAC, SAF, SAH, SAJ, SAP, SAT, SAZ Families
  - SWG, SWB, SWW, SWT, SWF, SWI, SWH, SWR, SWD, SWX, SWM, SWF Families
  - SUF, Uni-Guide™ Waveguide Connector Family
- Due to the nature of passive products, many of models are readily offered as flight units once the proper environmental testing is performed.

# CONCLUSIONS

- Eravant as a company has a proven record of delivering space ready solutions on time and within customer specifications.
- Eravant is ready to offer microwave and millimeterwave component and sub-assembly solutions to any space and aerospace system applications in the frequency range of DC to 220 GHz.
- More information can be found [here](#).