

ERA ∇ ANT

FORMERLY SAGE MILLIMETER



VNA FREQUENCY EXTENDERS

STO SERIES CONFIGURATION GUIDE

PRODUCT BROCHURE

CONTENTS

03

Introduction

04

Dual Tx/Rx Frequency Extenders

04

Amplitude Control

05

Tx/Rx and Rx Frequency Extenders

05

Tx/Ref and Rx Frequency Extenders

06

20 GHz VNA Frequency Extenders Selection Chart

07

Test and Measurement Accessories

INTRODUCTION

The STO series of VNA frequency extenders increases the reach of coaxial Vector Network Analyzers to millimeter-wave frequencies. Three different STO configurations are offered for waveguide bands from 50 to 330 GHz. The most versatile STO configuration is the Transmit/Receive (TX/RX) version. More specialized versions include the Receive-Only (RX) and Transmit/Reference (TX/Ref) configurations. Options include increased test-signal power. A level-setting attenuator for amplitude control is standard in TX/RX and TX/Ref models.

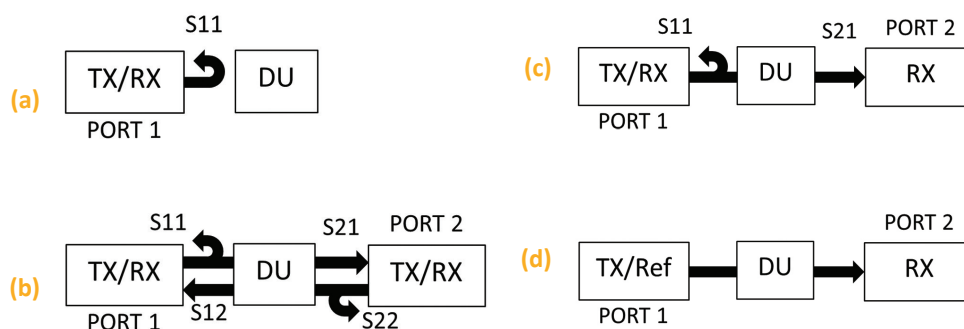

Fig. 1 - Possible VNA test systems using STO frequency extenders

A single TX/RX frequency extender provides only one VNA test port (Fig. 1a). The extender can only measure the reflection coefficient (S_{11}) of a Device Under Test (DUT). Measurement errors caused by the Source impedance mismatch are corrected by the VNA after calibration. The test results are referenced to the **LOAD** standard used during calibration.

A multiplier chain in the frequency extender takes the RF stimulus signal from the VNA and converts it to a higher test frequency (Fig. 2). Directional couplers sample the **Incident** signal applied to the DUT and the **Reflected** signal returned by the DUT. The sampled signals are fed to internal mixers that convert the Reference and Measured signals to the Intermediate Frequency of the VNA. A Local Oscillator signal from the VNA is multiplied by the frequency extender and applied to the mixers.

A one-port VNA system has limited applications for component testing. It is suitable for measuring the **Return Loss** of components such as antennas, connectors and adapters. Additional applications include **Reflectometry** measurements of materials and structures. Available options include increased test signal power, achieved by providing additional amplification between the source frequency multiplier and the directional couplers that sample the Incident and Reflected test signals. A level-setting attenuator is provided for controlling the test signal amplitude. Test signal power cannot be controlled by varying the amplitude of the RF stimulus signal because the frequency extender requires a limited range of input power to operate within specifications.

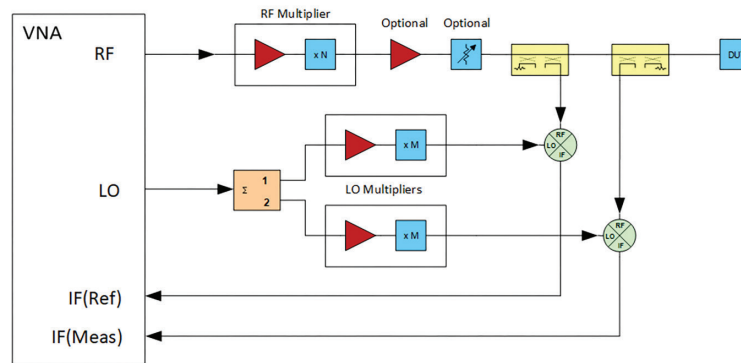

Fig. 2 - TX/RX Extender

FREQUENCY-EXTENDED VNA TEST SYSTEMS

Dual TX/RX Frequency Extenders

A common test setup uses a pair of TX/RX frequency extenders connected to the VNA (Fig. 1b). The resulting test system supports full two-port network measurements without having to reverse the DUT during the procedure. The system is ideal when all four scattering parameters are frequently of interest.

For example, components such as isolators and amplifiers are typically evaluated for return loss (S_{11} and S_{22}), insertion loss or gain (S_{21}), and isolation (S_{12}). The ability to fully characterize components without reversing their position during tests is a major benefit of having a bi-directional test system.

For many system designers, only knowing the forward gain (S_{21}) of an amplifier is not sufficient. If the amplifier is potentially unstable and it will be connected directly to components with poor return loss at some frequencies (i.e. filters), the amplifier may oscillate. As a result, all four scattering parameters (S_{11} , S_{12} , S_{21} and S_{22}) are often needed to predict the stability and performance of an amplifier when it is integrated into a system

Amplitude Control

All amplifiers have an acceptable range of input signal amplitude. When a low-noise or high-gain amplifier is tested, it helps to have a level-setting attenuator in the frequency extender connected to the amplifier input. The attenuator limits the test signal power and avoids over-driving the amplifier. Amplitude control also facilitates measuring the 1-dB compression point of amplifiers.

Components with high attenuation in one or both directions of signal flow are often challenging to measure accurately. Examples include filters, attenuators, isolators and switches. To produce a measurable signal at the receiver, increased signal power may be needed. A higher-power amplifier may also require a larger test signal to reach its 1-dB compression point. In such cases a TX/RX frequency extender configured for higher signal power may be selected. The included level-setting attenuator preserves the system's ability to measure low-power amplifiers.

TX/RX and RX Frequency Extenders

A Receive-Only (RX) frequency extender is a single-channel unit that only detects the received signal (Fig. 3). When TX/RX and RX frequency extenders are combined, the resulting test system is capable of measuring S11 and S21 (Fig. 1c). The test system corrects for Source and Load mismatch errors. Measurements of S22 and S12 require reversing the orientation of the DUT. For maximum test system capability, the TX/RX unit should be equipped with increased test signal power.

The TX/RX and RX frequency extender setup is ideal for antenna test ranges because it can simultaneously measure Return Loss and Antenna Gain. The Antenna Under Test is connected to the TX/RX frequency extender while a receiving antenna is attached to the RX frequency extender. The TX/RX unit should provide increased signal power to compensate for the path loss between antennas.

TX/Ref and RX Frequency Extenders

A VNA test system may also be realized by combining TX/Ref and RX frequency extenders (Fig. 1d). A TX/Ref frequency extender only measures the incident signal applied to the DUT (Fig. 4). It does not measure the reflected signal. As a result, the setup cannot measure S11 or correct for Source and Load impedance mismatch errors. The system can only measure the **Response** of a DUT with the Source and Load impedances of the frequency extenders possibly having some influence on the test results.

The TX/Ref and RX frequency extender setup may be used in antenna test ranges to measure Antenna Gain, but without the ability to correct errors caused by impedance mismatches between the Antenna Under Test and the connected frequency extender. The TX/Ref frequency extender should provide increased test signal power to compensate for the path loss between antennas.

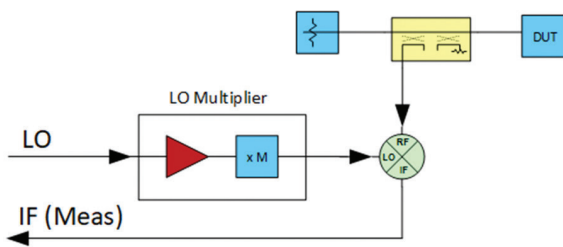

Fig. 3 - RX Extender

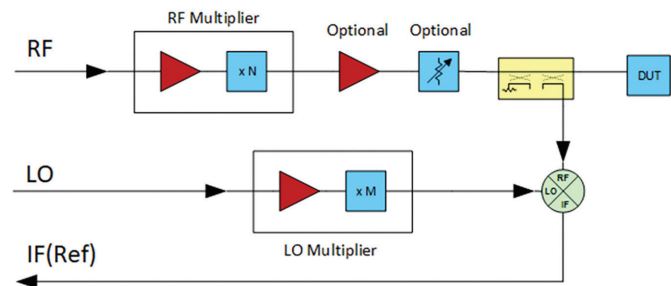

Fig. 4 - TX/REF Extender

20 GHz VNA FREQUENCY EXTENDERS SELECTION CHART

| STO System Configuration: | | | | |
|--|---|---|--|------------------------|
| Measurement Capability: | Full two-port measurements S11, S21, S12, S22 | Reflection and Transmission S11, S21 | Response Only (no correction for source or load mismatch) | Reflection Only |
| WR-03 220-330 GHz | STO-03203N05-CM-E1 (1 of 2) STO-03203N05-C-E1 (2 of 2) STO-03203N05-CMC-S1 (Pair) | STO-03203N05-CM-E1 (1 of 2) STO-03203N05-R-E1 (2 of 2) | STO-03203N05-TM-E1 (1 of 2) STO-03203N05-R-E1 (2 of 2) | STO-03203N05-CM-E1 |
| WR-05 140-220 GHz | STO-0520300-CM-E1 (1 of 2) STO-0520300-C-E1 (2 of 2) STO-0520300-CMC-S1 (Pair) | STO-0520300-CM-E1 (1 of 2) STO-0520300-R-E1 (2 of 2) | STO-0520300-TM-E1 (1 of 2) STO-0520300-R-E1 (2 of 2) | STO-0520300-CM-E1 |
| WR-06 110-170 GHz | STO-0620300-CM-E1 (1 of 2) STO-0620300-C-E1 (2 of 2) STO-0620300-CMC-S1 (Pair) | STO-0620300-CM-E1 (1 of 2) STO-0620300-R-E1 (2 of 2) | STO-0620300-TM-E1 (1 of 2) STO-0620300-R-E1 (2 of 2) | STO-0620300-CM-E1 |
| WR-08 90-140 GHz | STO-0820300-CM-E1 (1 of 2) STO-0820300-C-E1 (2 of 2) STO-0820300-CMC-S1 (Pair) | STO-0820300-CM-E1 (1 of 2) STO-0820300-R-E1 (2 of 2) | STO-0820300-TM-E1 (1 of 2) STO-0820300-R-E1 (2 of 2) | STO-0820300-CM-E1 |
| WR-10 75-110 GHz | STO-1020305-CM-E1 (1 of 2) STO-1020305-C-E1 (2 of 2) STO-1020305-CMC-S1 (Pair) | STO-1020305-CM-E1 (1 of 2) STO-1020305-R-E1 (2 of 2) | STO-1020305-TM-E1 (1 of 2) STO-1020305-R-E1 (2 of 2) | STO-1020305-CM-E1 |
| WR-10 75-110 GHz (High Power) | STO-1020313-CM-E1 (1 of 2) STO-1020313-C-E1 (2 of 2) STO-1020313-CMC-S1 (Pair) | STO-1020313-CM-E1 (1 of 2) STO-1020313-R-E1 (2 of 2) | STO-1020313-TM-E1 (1 of 2) STO-1020313-R-E1 (2 of 2) | STO-1020313-CM-E1 |
| WR-12 60-90 GHz | STO-1220305-CM-E1 (1 of 2) STO-1220305-C-E1 (2 of 2) STO-1220305-CMC-S1 (Pair) | STO-1220305-CM-E1 (1 of 2) STO-1220305-R-E1 (2 of 2) | STO-1220305-TM-E1 (1 of 2) STO-1220305-R-E1 (2 of 2) | STO-1220305-CM-E1 |
| WR-12 60-90 GHz (High Power) | STO-1220315-CM-E1 (1 of 2) STO-1220315-C-E1 (2 of 2) STO-1220315-CMC-S1 (Pair) | STO-1220315-CM-E1 (1 of 2) STO-1220315-R-E1 (2 of 2) | STO-1220315-TM-E1 (1 of 2) STO-1220315-R-E1 (2 of 2) | STO-1220315-CM-E1 |
| WR-15 50-75 GHz | STO-1520305-CM-E1 (1 of 2) STO-1520305-C-E1 (2 of 2) STO-1520305-CMC-S1 (Pair) | STO-1520305-CM-E1 (1 of 2) STO-1520305-R-E1 (2 of 2) | STO-1520305-TM-E1 (1 of 2) STO-1520305-R-E1 (2 of 2) | STO-1520305-CM-E1 |
| WR-15 50-75 GHz (High Power) | STO-1520315-CM-E1 (1 of 2) STO-1520315-C-E1 (2 of 2) STO-1520315-CMC-S1 (Pair) | STO-1520315-CM-E1 (1 of 2) STO-1520315-R-E1 (2 of 2) | STO-1520315-TM-E1 (1 of 2) STO-1520315-R-E1 (2 of 2) | STO-1520315-CM-E1 |

Note - Optional attenuators can be removed from the TX/RX and TX/Ref models by removing designator "M" for example STO-1020313-TM-E1 would be STO-1020313-T-E1

TEST & MEASUREMENT ACCESSORIES

Calibration Kits

In addition to VNA frequency extenders, Eravant offers VNA calibration kits that cover waveguide bands from 50 to 330 GHz. The metrology grade calibration kits are designed and manufactured to work with all industry standard network analyzers. The calibration kits include one fixed short, one fixed matching load, three waveguide offset shims, two waveguide Quick-Connects, an assortment of waveguide screws and alignment pins, a hex screwdriver, and a USB drive with calibration data. Everything is provided in a ruggedized carrying case.

The calibration kits use durable Beryllium Copper alloy with hard gold plating to provide superior electrical and mechanical performance. NIST-traceable calibration data and certification are available for an added fee.



Wave-Glide™ Rail System

Eravant's Wave-Glide™ Rail System is a patent-pending positioning apparatus that enhances the operation of VNA test setups equipped with frequency extenders. They maintain precise mechanical alignment between waveguide test ports to greatly streamline calibration and test procedures while increasing measurement robustness, accuracy and productivity.

Standard mounting plates accommodate Eravant frequency extenders and those of other major manufacturers. Custom designs are available per customer specifications.

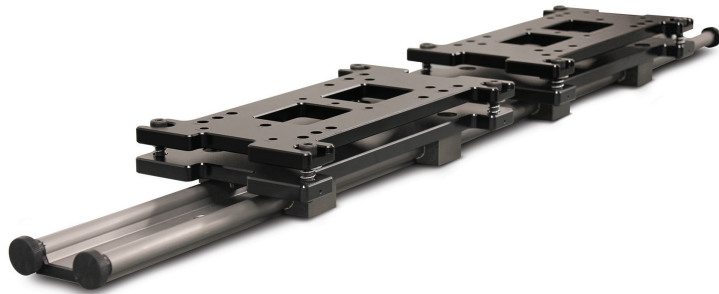

Proxi-Flange™ Contactless Flange

VNA test ports equipped with Proxi-Flange™ waveguide sections provide highly effective electrical connections without using waveguide screws. The patent-pending technology eliminates the need for perfect mechanical connections between the VNA test ports and the DUT. Contrary to conventional waveguide flanges that must be fully mated and mechanically secured using cumbersome screws and rigorously followed tightening procedures, Proxi-Flange™ test ports need only be placed in close proximity to the DUT.

Proxi-Flange™ waveguide sections greatly extend the life of VNA test ports, and they virtually eliminate the risk of mechanically damaging calibration standards or the components being tested. They are available for waveguide bands from 18 to 330 GHz.





For more information on Eravant's products, applications, or services, please visit: www.eravant.com
501 Amapola Avenue, Torrance, CA 90501 | 424-757-0168 | support@eravant.com
This information is subject to change without notice. Copyright © 2022 Eravant